



Smart for Greenlife!

Advantages

- Meet ISO 4064 Class C (can detect very small amount of water flow) and R250 ratio standard
- Gold Medal Winner of 2013 INPEX(Invention & New Product Exposition) in Pennsylvania
- The world's first magnet-free electronic water meter
- Tamper-proof to make water thief impossible
- Direct reading LCD display-IP 68 electronic registers and protected from fogging

Applications

- Water metering for smart buildings, apartments, universities, Commercial.
- Measurement of low and high flowrates
- For leakage detection, control and prevention

Features

- Ready for use with DAE AMR100-D (Display and communication module for single digital water meter) and AMR-D (for 8 water meters) for remote reading
- Build-in 8 years battery lifespan
- Gear-free with electronic sensing devices
- Multi-point flow rates calibration
- Suitable for submerged condition; Protection class IP68
- Used materials are temperature resistant up to 60°C
- Max. working pressure: 284 psi
- Max. ambient temperature: 70°C
- Meter body: Corrosion proof copper alloy
- Intelligent Management Functions (Totalizer mode; Forward totalizer mode; Reverse totalizer mode; Flow rate mode; Management mode; Leakage days; Reverse flow days; Tamper-proof days; Low voltage days; Monthly water consumption logs ; MNF (Minimum Nighttime Flow) logs)

Models

Model	DN mm (inch)
TH15	15 (½")
TH20	20 (¾")
TH25	25 (1")
TH50	50 (2")

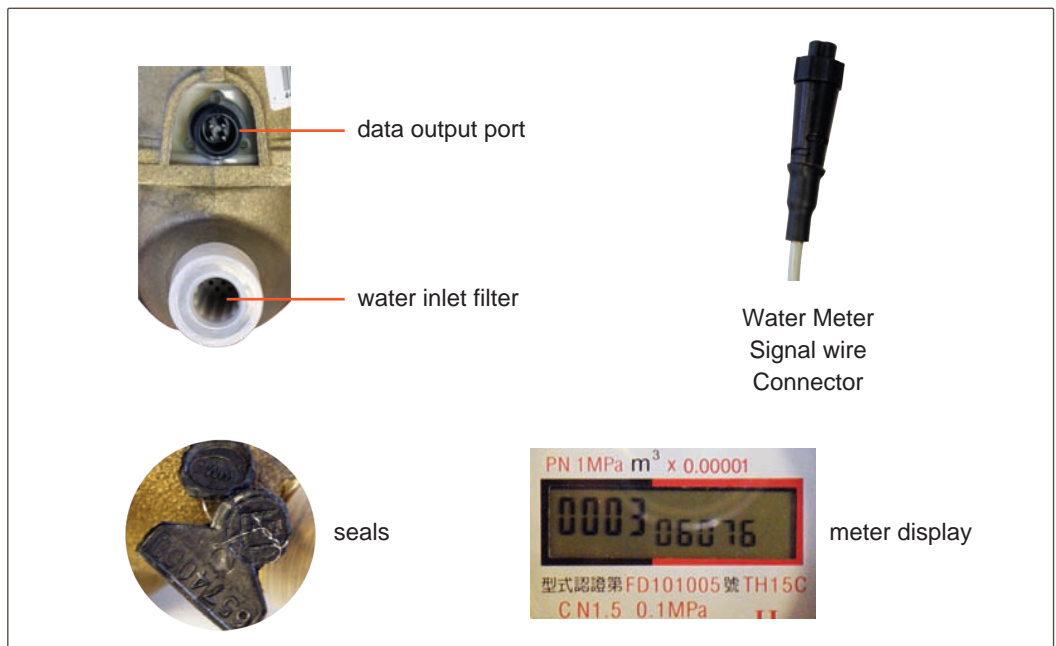

Specifications

Model	TH15	TH20	TH25	TH50
DN (inch)	½"	¾"	1"	2"
Nominal Flow Rate (m³/h)	1.5	2.5	3.5	15
Maximum Flow Rate (m³/h)	3	5	7	30
Display Digits	1234. ₁₂₃₄₅	1234. ₁₂₃₄₅	12345. ₁₂₃₄	123456. ₁₂₃
Accuracy	±0.5% @ nominal flow			
Fluid Temperature	Cold Water Meter: < 140°F (60°C)			
Ambient Temperature	-13°F ~ 158°F (-25°C ~ 70°C)			
Maximum Pressure	284 psi			
Ingress Protection	Conforms to IEC60529 IP68 ingress protection against dirt and water; unrelated to magnetic interference of impeller			
Suitable for Fluid Type	Clean water			
Body Material	Copper alloy			
Battery Life	Built in lithium battery, estimated battery life of 20 years, calculated based on a constant polling cycle of once every 2 minutes			
Communication Distance	Up to 164 feet (50 meters) to AMR100-D or AMR-D			

Dimensions

Model	D mm (inch)	Length (L) mm (inch)	Width (W) mm (inch)	Height (H1) mm (inch)	Height (H2) mm (inch)	Weight kg (lb)
TH15	15 (½")	165 (6.5)	90 (3.5)	40 (1.6)	80 (3.1)	1.8 (3.96)
TH20	20 (¾")	190 (7.5)	90 (3.5)	37 (1.5)	80 (3.1)	1.9 (4.18)
TH25	25 (1")	210 (8.3)	90 (3.5)	42 (1.7)	85 (3.3)	2.2 (4.84)
TH50	50 (2")	270 (10.6)	123 (4.8)	58 (2.3)	138 (5.4)	6.38 (14.04)

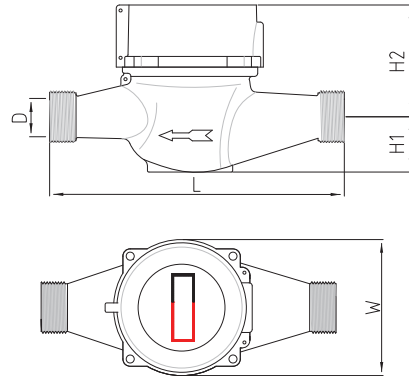

Related Products

Display and Communication Module for Digital Water Meter



AMR100-D
Single Channel



AMR-D
8 Channels

- Supports digital water meter
- Display always in sync with meter even during power outage
- Modbus over RS485 interface for communication with host computer
- Communication distance between module and digital water meter should be up to 164 feet (50 meters, using UL2464 shield twisted pair)

* Please see AMR100-D & AMR-D datasheet for details.

* Specifications are subject to change without notice, this is a preliminary datasheet and for reference only.